

**SPECIFICATION RW-2514**  
Document Number 108-121017

**NBC MARKER SYSTEM  
(Ladder Form)  
NBC-SCE**

**1. SCOPE**

NBC-SCE Markers are designed for use where extreme resistance to cleaning solvents is needed. The mark is permanent upon shrinking the Marker. The markers are suitable for use in wire harness systems requiring high fluid resistance and resistance to the effects of nuclear, biological and chemical agent exposure and decontamination. The markers should be used with an appropriate transparent oversleeve (TMS-CCUV) whose ends are sealed with an appropriate epoxy adhesive.

**1.1 CLASSIFICATION**

**1.1.1 Markers**

The Markers shall be fabricated from radiation crosslinked modified fluoropolymer tubing, flattened and mounted on a carrier in a ladder configuration.

**1.1.2 System Equipment**

The recommended Printer Ribbon Systems for use with NBC-SCE are shown in the latest version of document 411-121005 Identification Printer Product Ribbon Matrix. System performance is evaluated in this specification

**REVISION HISTORY**

Revision Number	Description of change	Date	Incorporated By
1	Replaces RT-1809 issue 2	July 2004	-
2	Format update	February 2014	M Priddle

While TE Connectivity has made every reasonable effort to ensure the accuracy of the information in this specification, TE Connectivity does not guarantee that it is error-free, nor does TE Connectivity make any other representation, warranty or guarantee that the information is accurate, correct, reliable or current. TE Connectivity reserves the right to make any adjustments to the information contained herein at any time without notice. TE Connectivity expressly disclaims all implied warranties regarding the information contained herein, including, but not limited to, any implied warranties of merchantability or fitness for a particular purpose. The dimensions in this document are for reference purposes only and are subject to change without notice. Specifications are subject to change without notice. Consult TE Connectivity for the latest dimensions and design specifications.

## 2. APPLICABLE DOCUMENTS

This specification takes precedence over documents referenced herein. Unless otherwise specified, the latest issue of the referenced documents applies. The following documents form a part of this specification.

### 2.1 GOVERNMENT FURNISHED DOCUMENTS

#### Military

MIL-STD-202	Test Methods for Electronic and Electrical Component Parts
MIL-H-5606	Hydraulic Fluid, Petroleum Base, Aircraft, Missile and Ordnance
MIL-T-5624	Turbine Fuel, Aviation, Grades JP-4 and JP-5
MIL-L-7808	Lubricating Oil, Aircraft Turbine Engine, Synthetic Base
MIL-A-8243	Anti-Icing and Deicing-Defrosting Fluid

### 2.2 OTHER PUBLICATIONS

#### American Society for Testing and Materials (ASTM)

ASTM D 876	Testing Non-rigid Vinyl Chloride Polymer Tubing used for Electrical Insulation
ASTM D 2671	Testing Heat-Shrinkable Tubing for Electrical Use
ASTM G 21	Recommended Practice for Determining Resistance of Synthetic Polymeric Materials to Fungi

#### SAE International

SAE-AS-81531	Marking of Electrical Insulating Materials
--------------	--

## 3. REQUIREMENTS

### 3.1 MATERIAL

The sleeving shall be fabricated from irradiated, thermally-stabilized, modified polyvinylidene fluoride compound. It shall be homogeneous and essentially free from flaws, defects, pinholes, bubbles, seams, cracks or inclusions.

### 3.2 COLOR

The markers shall be white, unless otherwise specified.

### 3.3 FORM

The sleeves shall be cut lengths mounted on a carrier in a ladder configuration in accordance with Figure 1 and shall be suitable for automatic marking with systems recommended in Doc 411-121005.

### 3.4 PROPERTIES

The sleeves shall meet the requirements of Table 3.

## 4. QUALITY ASSURANCE PROVISIONS

### 4.1 CLASSIFICATION OF TESTS

#### 4.1.1 Qualification Tests

Qualification tests are those performed on finished markers or marker material submitted for qualification as a satisfactory product and shall consist of all tests listed in this specification.

#### 4.1.2 Acceptance Tests

Acceptance tests are those performed on finished markers submitted for acceptance under contract. Acceptance tests shall consist of the following:

Dimensions

Longitudinal Change

Print Performance (4.3.6.2)

### 4.2 SAMPLING INSTRUCTIONS

#### 4.2.1 Qualification Test Samples

Qualification test samples shall consist of 50 feet (15 m) of continuous marker material and the appropriate number of finished markers necessary to run all tests. Qualification of any one size shall qualify all sizes.

#### 4.2.2 Acceptance Test Samples

Acceptance test samples shall consist of the appropriate number of finished markers necessary to run the specified tests.

### 4.3 TEST PROCEDURES

Unless otherwise specified, the markers shall be removed from the carrier and recovered for 3 minutes at  $200 \pm 5^{\circ}\text{C}$  ( $392 \pm 9^{\circ}\text{F}$ ) for testing. All ovens shall be of the mechanical convection type, in which air passes the specimens at a velocity of 100 to 200 feet (30 to 60 m) per minute. Where required by test method limitations, testing shall be done on continuous marker material.

#### 4.3.1 Dimensions, Dimensional Recovery and Longitudinal Change

Test three markers in accordance with ASTM D 2671 for dimensions as supplied, dimensions as recovered and longitudinal change. Recover the specimens for 3 minutes at  $200 \pm 5^{\circ}\text{C}$  ( $392 \pm 9^{\circ}\text{F}$ ).

#### 4.3.2 Tensile Strength and Ultimate Elongation

Test three specimens for tensile strength and ultimate elongation. The specimens shall be in accordance with ASTM D 2671, using 1-inch (25-mm) bench marks and a 1-inch (25-mm) initial jaw separation, and a jaw separation speed of 2 inches (50-mm) per minute.

#### 4.3.3 Low Temperature Flexibility

Prepare test strips as follows: Recover three 6-inch (150-mm) long sections of tubing, and while they are still hot, slit longitudinally, and flatten between metal plates. Cool to room temperature, remove the metal plates, and cut into 1/4-inch (6-mm) wide strips.

Place the specimens in a cold chamber with a 3/4-inch (19.1-mm) mandrel at  $-55 \pm 2^{\circ}\text{C}$  ( $-67 \pm 4^{\circ}\text{F}$ ) for 4 hours. While still in the cold chamber, and at this same temperature, wrap the specimens around the mandrel not less than 360 degrees in approximately 2 seconds.

#### 4.3.4 Heat Shock

Mark six specimens per Section 4.3.6 and remove from the carrier. Condition the specimens for 4 hours at  $275 \pm 3^{\circ}\text{C}$  ( $527 \pm 5^{\circ}\text{F}$ ). Remove the specimens from the oven, cool to room temperature and bend three specimens through 90 degrees, in approximately 2 seconds, over a 3/4-inch ( $19.1\text{ mm}$ ) mandrel. Visually examine the specimens for evidence of dripping, flowing or cracking. Disregard any side cracking caused by flattening of the specimens on the mandrel. Test the other three specimens for print performance in accordance with Section 4.3.6.2.

**TABLE 1**  
**SUGGESTED STRANDED WIRE SIZE**  
**FOR HEAT AGING & TEMPERATURE CYCLING**

Tubing Size	Suggested Stranded Wire Size	
	AWG Size -- Stranding	
1/4	12	19/25
1/2	8	7 x 19/29

#### 4.3.5 Heat Aging

Mark specimens per Section 4.3.6. as follows: For sizes through 1/2, recover six specimens over a stranded wire as described in Table 1. For sizes above 1/2, cut six 1/4-inch ( $6.35\text{-mm}$ ) wide strips from the marked, recovered specimens. Condition all specimens for 168 hours at  $225 \pm 3^{\circ}\text{C}$  ( $437 \pm 5^{\circ}\text{F}$ ) and examine for cracks.

Test three specimens shrunk on the stranded wire for print performance in accordance with Section 4.3.6.2. Bend the other three specimens through 90 degrees, in approximately 2 seconds over a 3/4-inch ( $19.1\text{-mm}$ ) mandrel, and examine for cracks. Test three specimens in strip form for print performance in accordance with Section 4.3.6.2 and bend three through 90 degrees over a 3/4-inch ( $19.1\text{-mm}$ ) mandrel and examine for cracks.

#### 4.3.6 Print Performance - Legibility and Durability

Mark nine finished markers with an appropriate Print system in accordance with Section 1.1.2. Print random characters across the length of each marker to within 1/4 inch ( $6\text{ mm}$ ) of both ends. Remove the specimens from the carrier and recover them for 3 minutes at  $200 \pm 5^{\circ}\text{C}$  ( $392 \pm 9^{\circ}\text{F}$ ).

4.3.6.1 Test three specimens in accordance with U.L. Standard 224. Examine the specimens for legibility at a distance of 14 inches ( $355\text{ mm}$ ).

4.3.6.2 Test three specimens for print adherence in accordance with Paragraph 4.6.2 of SAE-AS-81531. Perform the number of rubs specified in Table 3 of this specification and examine the specimens for legibility at a distance of 14 inches ( $355\text{ mm}$ ).

4.3.6.3 Test three specimens for solvent resistance in accordance with MIL-STD-202 Method 215, except perform the number of strokes specified in Table 3. Examine the specimens for legibility at a distance of 14 inches ( $355\text{ mm}$ ).

#### 4.3.7 Temperature Cycling

Mark specimens per Section 4.3.6. as follows: For sizes through 1/2, recover six specimens over a stranded wire as described in Table 1. For sizes above 1/2, cut six 1/4-inch ( $6.35\text{-mm}$ ) wide strips from the marked, recovered specimens. Subject all specimens to six temperature

cycles. One cycle shall be as follows: 0.5 hours immersed in liquid nitrogen at  $-196 \pm 5^{\circ}\text{C}$  ( $-321 \pm 9^{\circ}\text{F}$ ) followed immediately by 0.5 hours in a  $200 \pm 5^{\circ}\text{C}$  ( $392 \pm 9^{\circ}\text{F}$ ) forced air oven. After the final cycle, allow the specimens to stabilize to room temperature.

Test three specimens shrunk on the stranded wire for print performance in accordance with Section 4.3.6.2. Bend the other three specimens through 90 degrees, in approximately 2 seconds over a 3/4-inch (19.1-mm) mandrel, and examine for cracks. Test three specimens in strip form for print performance in accordance with Section 4.3.6.2 and bend three through 90 degrees over a 3/4-inch (19.1-mm) mandrel and examine for cracks.

#### 4.3.8 Fluid Resistance

Completely immerse three specimens, marked and prepared in accordance with Section 4.3.6, in each fluid listed in Table 3 for 24 hours at  $23 \pm 3^{\circ}\text{C}$  ( $73 \pm 5^{\circ}\text{F}$ ). The volume of the fluid shall be not less than 20 times that of the specimens. After immersion, lightly wipe the specimens and allow to air dry for 30-60 minutes at room temperature. Test the specimens for print performance in accordance with Section 4.3.6.2.

#### 4.3.9 Radiation Resistance

Three specimens prepared in accordance with Section 4.3.2 shall be subjected to gamma radiation for a total dosage of 10 Mrad at a rate of less than 0.5 Mrad per hour. The specimens shall be measured for tensile strength and ultimate elongation in accordance with Section 4.3.2.

#### 4.4 REJECTION AND RETEST

Failure of any sample to conform to any of the requirements of this specification sheet shall be cause for rejection of the lot represented. Markers which have been rejected may be replaced or reworked to correct the defects and resubmitted for acceptance. Before resubmitting, full particulars concerning previous rejection and action taken to correct the defects shall be furnished to the inspector.

### 5. PREPARATION FOR DELIVERY

#### 5.1 FORM

Markers shall be supplied on a carrier, either wound on spools, or in strips.

#### 5.2 PACKAGING

Packaging shall be in accordance with good commercial practice.

#### 5.3 MARKING

Each container of markers shall be identified with the product designation, size, quantity, manufacturer's identification and lot number.

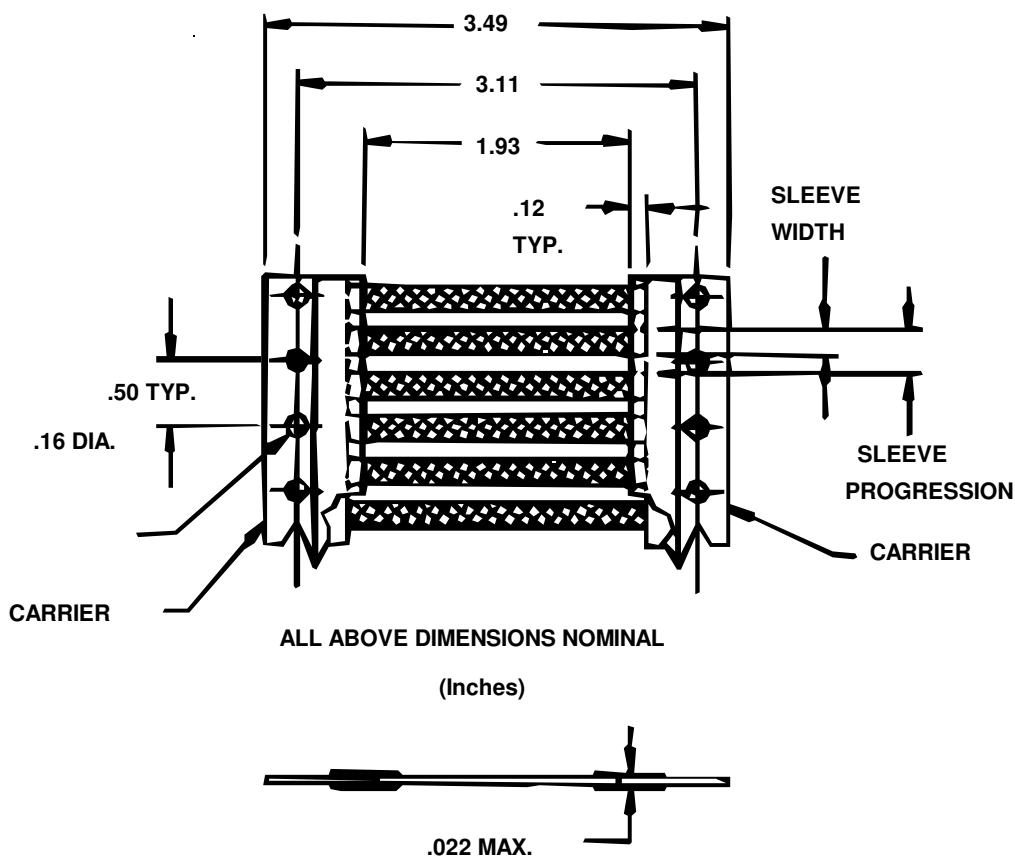

FIGURE 1

**TABLE 2**  
**Marker Dimensions and Configuration**

Part Number	Expanded I.D. Minimum		Recovered I.D. Maximum		Expanded Sleeve Width Minimum		Recovered Wall Thickness		Sleeve Progression Nominal	
	in.	mm.	in.	mm.	in.	mm.	in.	mm.	in.	mm.
NBS-SCE 1/8	.135	3.43	.062	1.59	0.23	5.8	.015 ± .003	.38 ± .08	0.50	12.7
NBC-SCE 1/4	.250	6.35	.125	3.18	0.42	10.7	.015 ± .003	.38 ± .08	0.67	17.0
NBC-SCE 1/2	.500	12.70	.250	6.35	0.80	20.3	.015 ± .003	.38 ± .08	1.17	29.7
NBC-SCE 3/4	.750	19.05	.375	9.53	1.20	30.5	.015 ± .003	.38 ± .08	1.67	42.4
NBC-SCE 1	1.000	25.40	.500	12.70	1.59	40.4	.017 ± .004	.43 ± .10	2.00	50.8
NBC-SCE 1-1/2	1.500	38.10	.750	19.05	2.37	60.2	.017 ± .004	.43 ± .10	2.83	71.9

**TABLE 3**  
**Requirements**

PROPERTY	UNIT	REQUIREMENT	TEST METHOD
<b>PHYSICAL</b>			
Dimensions	Inches ( <i>mm</i> )	In accordance with Table 2	Section 4.3.1 ASTM D 2671
Dimensional Recovery 3 minutes at 200 ± 5°C (392 ± 9°F)	Inches ( <i>mm</i> )	In accordance with Table 2	
Longitudinal Change 3 minutes at 200 ± 5°C (392 ± 9°F)	Percent	20 maximum	
Tensile Strength	psi ( <i>MPa</i> )	3500 minimum (24.1)	Section 4.3.2
Ultimate Elongation	Percent	200 minimum	ASTM D 2671
Specific Gravity	---	1.8 maximum	ASTM D 2671
Low Temperature Flexibility 4 hours at -55 ± 1°C (-67 ± 2°F)	---	No cracking	Section 4.3.3
Heat Shock 4 hours at 275 ± 3°C (527 ± 5°F) Followed by test for: Print Performance	---	No dripping, flowing, or cracking	Section 4.3.4
	Rubs	50 minimum, legible	Section 4.3.6.2
Heat Aging 168 hours at 225 ± 2°C (437 ± 4°F) Followed by test for: Print Performance	---		Section 4.3.5
	Rubs	50 minimum, legible	Section 4.3.6.2
Print Performance (U.L. Subject 224) (SAE-AS-81531) (MIL-STD-202)	Rubs	100 minimum, legible	Section 4.3.6 Section 4.3.6.1
	Rubs	100 minimum, legible	Section 4.3.6.2
	Strokes	100 minimum, legible	Section 4.3.6.3
Temperature Cycling 6 cycles of: 0.5 hr at -196 ± 5°C (-321 ± 9°F) 0.5 hr at 200 ± 5°C (392 ± 9°F) Followed by test for: Print Performance	--	No cracking	Section 4.3.7
	Rubs	50 minimum, legible	Section 4.3.6.2
<b>ELECTRICAL</b>			
Dielectric Strength	Volts/mil ( <i>kV/mm</i> )	600 minimum (23.6)	ASTM D 2671
Volume Resistivity	ohm-cm	10 <sup>12</sup> minimum	ASTM D 2671
<b>CHEMICAL</b>			
Corrosive Effect 16 hours at 200 ± 2°C (392 ± 4°F)	---	Non-corrosive	ASTM D 2671 Procedure A
Flammability (ASTM D 876) Average time of			
	Seconds	15 maximum	ASTM D 876
Fungus Resistance	---	Rating of 1 or less	ASTM G 21

**TABLE 3**  
**Requirements**  
(continued)

PROPERTY	UNIT	REQUIREMENT	TEST METHOD
<b>CHEMICAL</b> (continued) Fluid Resistance 24 hours at $23 \pm 3^{\circ}\text{C}$ ( $73 \pm 5^{\circ}\text{F}$ ) in: JP-4 Fuel (MIL-T-5624) Hydraulic Fluid (MIL-H-5606) Skydrol* 500 Aviation Gasoline (100/130) Lubricating Oil (MIL-L-7808) Salt Water (5% salt) Anti-Icing Fluid (MIL-A-8243) Followed by test for: Print Performance	--	--	Section 4.3.8
Print Performance	Rubs	20 minimum, legible	Section 4.3.6.2
<b>NUCLEAR</b> Radiation Resistance Followed by tests for: Tensile Strength Ultimate Elongation	psi (MPa) percent	3000 minimum (24.1) 150 minimum	Section 4.3.9

\*Trademark of the Monsanto Company